

RECORD 1S		SPECIFICATION						
1	Manufacturer	BALKANCAR RECORD JSC						
2	Type			GV 3630.30.5MC S CNG	GV 3632.30.5MC S CNG	GV 3636.30.5MC S CNG	GV 3638.30.5MC S CNG	
3	Load capacity	Q	kg	1250	1500	1750	2000	
4	Load center	C	Load center to fork face	mm	500			
5	Drive unit		Battery / diesel / LPG		gas (CNG) / gasoline			
6	Type of operation		Pedestrian / rider seated / stand-on		Rider seated			
7	Lift	h_3	Lift height	mm	3000 ¹⁾			
8	Overall dimensions	L_2	Length	mm	2150	2200	2230	2290
9		B	Width	mm	1180			
10		h_6	Height of overhead guard	mm	2080			
11	Internal combustion engine		Manufacturer, type (diesel/LPG)		TOYOTA (CNG / gasoline)			
12	Transmission		Type, speeds (forward/backward)		Hydrodynamic			

1) For other lift heights refer to MAST table. Size h_4 does not include a load backrest. When a backrest is fitted add + 680 mm.

* Forklifts in accordance with BDS EN 1726-1.

* Other variants of specifications and characteristics are possible.

* Dimensions and parameters as shown are for reference only. They have been obtained under laboratory testing conditions. They could vary in accordance with the operation mode and the corresponding variants.

* Balkancar Rekord JSC reserves the right to introduce changes to the specifications and products without notice.

* The pictures and illustrations do not include all variants produced, additional equipment and accessories.

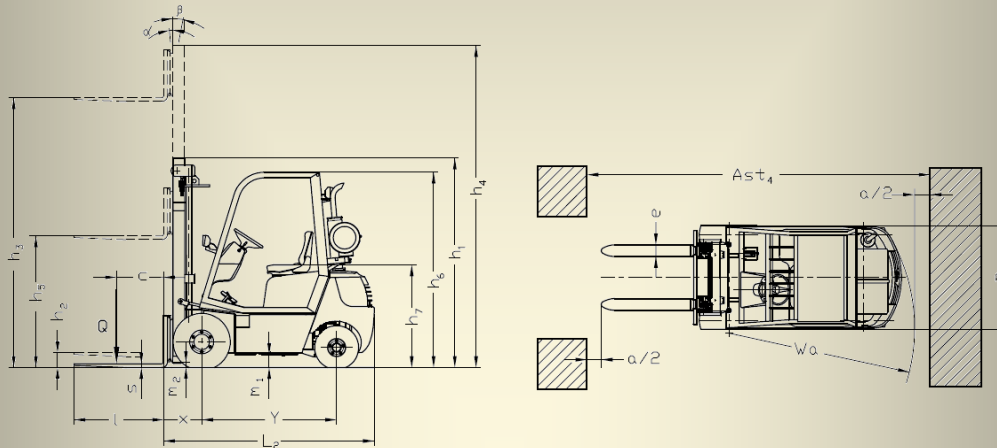

MAST

TYPE	LIFT HEIGHT h_3	HEIGHT, MAST LOWERED h_1	HEIGHT, MAST EXTENDED h_4	FREE LIFT h_2/h_5
------	----------------------	-------------------------------	--------------------------------	------------------------

SIMPLEX – 1,25/1,5/1,75/2,0 t FORKLIFT

(Two masts, Free lift)

30 S	3000	2080	3540	80
40 S	4000	2620	4555	130

DUPLEX – 1,25/1,5/1,75/2,0 t FORKLIFT

(Two masts, Extended free lift)

30 D	3000	2080	3580	1500
------	------	------	------	------

TRIPLEX – 1,25/1,5/1,75/2,0 t FORKLIFT

(Three masts, Extended free lift)

42 T	4200	2080	4800	1360
45 T	4500	2220	5220	1500
50 T	5000	2370	5670	1650
54 T	5400	2470	5990	1760
60 T	6000	2670	6590	1960